

CAD FILE:

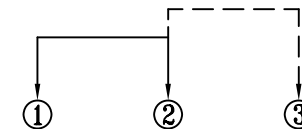

SCHEMATIC

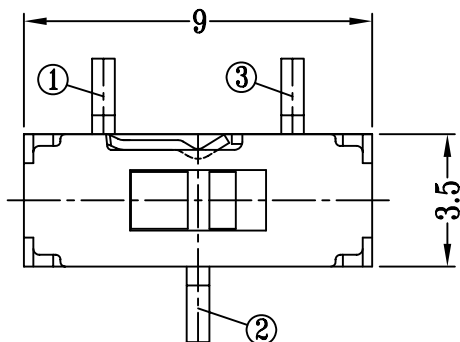
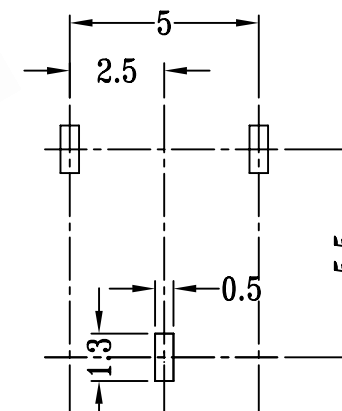
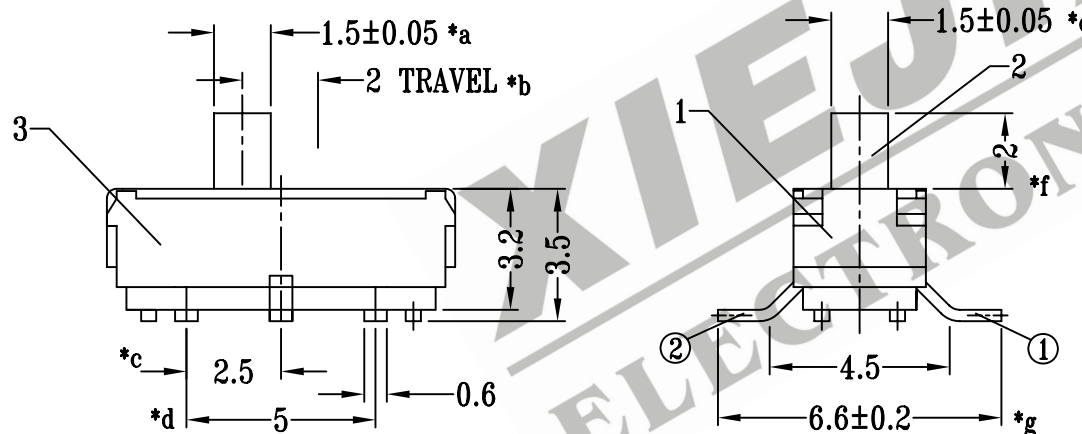

P.C.B LAYOUT

注：“\*”表示关键尺寸（5个）

8					TOLERANCE	SHENZHEN XIEJIA ELECTRONICS CO.,LTD.				
7					UNLESS SPECIFIED					
6					WITHIN: 1.5±0.1mm					
5					OVER : 1.5±0.2mm	ISSUE	DATE	DESCRIPTIONS	APPD.	
4	CONTACT	PBS	2	Ag CLAD	TITLE : MINI SLIDE SWITCH		UNIT : MM	DRWG NO.: XJ-DR-MS12D17-00		
3	CASE	NYLON+F.G/BRASS STRIP	1	BLACK/Ag PLATED OVER Ni PLATED	MODEL: MS-12D17		SCALE: 5 : 1	DWN.	ZHOUYU	2002-8-26
2	KNOB	NYLON+F.G	1	WHITE				CHK'D	FANGYING	2002-8-26
1	COVER	SUS	1	WASHING				APPD.	KANGXINAN	2002-8-26
NO.	PART NAME	MATERIAL	Q'TY	FINISHING	ALL MATERIALS MUST BE COMPLIANT TO ROHS					